

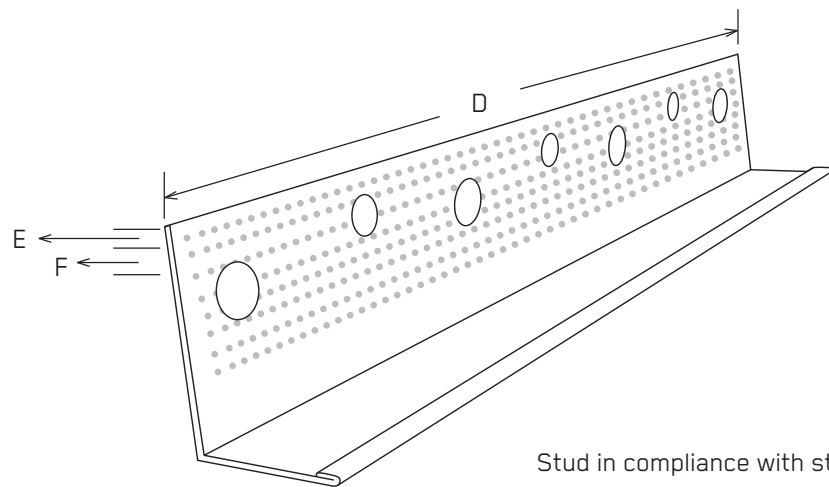

L-TRIM

SPECIFICATION SHEET

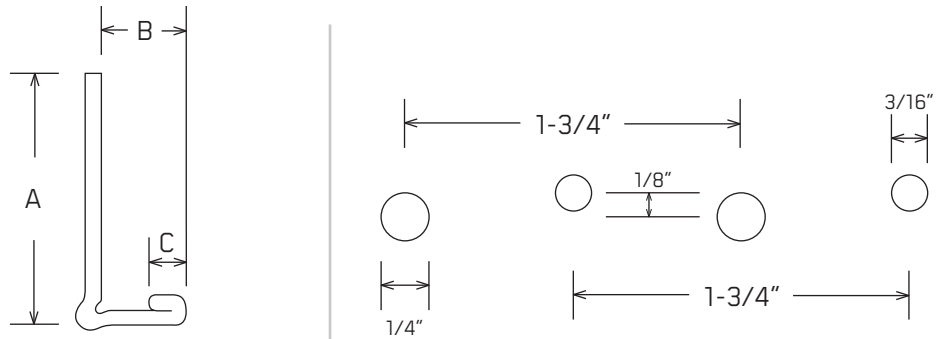

Stud in compliance with standards:
ASTM C1047

Legend:

	A	B	C	D	Thickness
ML38	1-1/4"	3/8"	1/8"	10'	0,13 Mils
ML12	1-1/8"	1/2"	1/8"	10'	0,13 Mils
ML58	1"	5/8"	1/8"	10'	0,13 Mils

E (Edge to 3/16" hole distance) = 1/8"

F (Edge to 1/4" hole distance) = 1/4"

Quebec
418-871-8088
800-871-5818
Boucherville
450-655-5100



Nov. 2017